

Vision	MISSION
We envision the Department as one of the best in the region with a stimulating environment to make an impact on and lead in the field through its Education and Research.	The mission of the Department is to provide an excellent and comprehensive education in the field of Electrical & Electronics Engineering which in turn moulds the students for a wide range of careers and to exhibit a high level of professionalism, ethical behavior and social responsibility.

Home Security system using internet of things - By Dr. K.Vijaya bhaskar

Abstract: IOT refers to the infrastructure of connected physical devices which is growing at a rapid rate as huge number of devices and objects are getting associated to the internet. Home security is a very useful application of IOT and we are using it to create an inexpensive security system for homes as well as industrial use. The system will inform the owner about any unauthorized entry or whenever the door is opened by sending a notification to the user. After the user gets the notification, it can take the necessary actions. The security system will use a micro controller known as Arduino to interface between the components, a magnetic Reed sensor to monitor the status, a buzzer for sounding the alarm, and a WiFi module.

1. Introduction

IOT or Internet of Things refers to the network of connected physical objects that can communicate and exchange data among themselves without the need of any human intervention. It has been formally defined as an "Infrastructure of Information Society", because IOT allows us to collect information from all kind of mediums such as humans, animals vehicles, kitchen appliances. Thus any object in the physical world which can be provided with an IP address to enable data transmission over a network can be made part of IOT system by embedding them with electronic hardware such as sensors, software and networking gear. IOT is different than Internet as in a way it transcends Internet connectivity by enabling everyday objects that uses embedded circuits to interact and communicate with each other utilizing the current Internet infrastructure. The term IOT and its conception can be traced back to 1985 when Peter T Lewis spoke about the concept during his speech at Federal Communications Commission (FCC). Since then the scope of IoT has grown tremendously as currently it consists of more than 12 billion connected devices and according to the experts it will increase to 50 billion by the end of 2025. The IoT infrastructure has helped by providing real time information gathering and analysis using accurate sensors and seamless connectivity, which help in making efficient decisions. With the advent of IoT both manufacturers and consumers have benefited. Manufacturers

have gained insight into how their products are used and how they perform out in the real world and increase their revenues by providing value added services which enhances and elongates the life cycle of their products or services. Consumers on the other hand have the ability to integrate and control more than one devices for a more customized and improved user experience.

An important factor to consider when we talk about home automation is security. Home security is a very important feature of home automation and maybe the most crucial one. Home security made a drastic changes in the past few decades and continue to advance much more in the coming years.

Previously home security systems meant having an alarm that would go off when somebody would break in but a smart secure home can do much more than that. Therefore, the main objective of our work is to design a system which can alert the owner and others of an intruder break-in by sending a notification to their smart phones.

This system will help the users to safeguard their homes by placing the system on the doors or Windows and monitoring the activity through their smart phones. The owner will also have the ability to stop or start the alarm remotely using just his smart phone. There has been an unprecedented growth in the number of devices being connected to the Internet since past few years.

All these devices connected to the internet are part of the IOT infrastructure which can that allows these devices to send and receive data among each other. This is why it is beneficial to use such an exiting infrastructure for designing the proposed security system. An alarm system that sounds the buzzer is of no use when a user is not present in the home to take action. when the owner is away communicate with each other.

The IoT network consists of embedded electronics, sensors and software from their home, they want to be assured that their home is protected by intruders and thieves while they are gone. This is why the proposed system keeps the owner informed in the real time about the security status of their home. The designed system informs the user as there is a break in so that the user can take necessary actions.

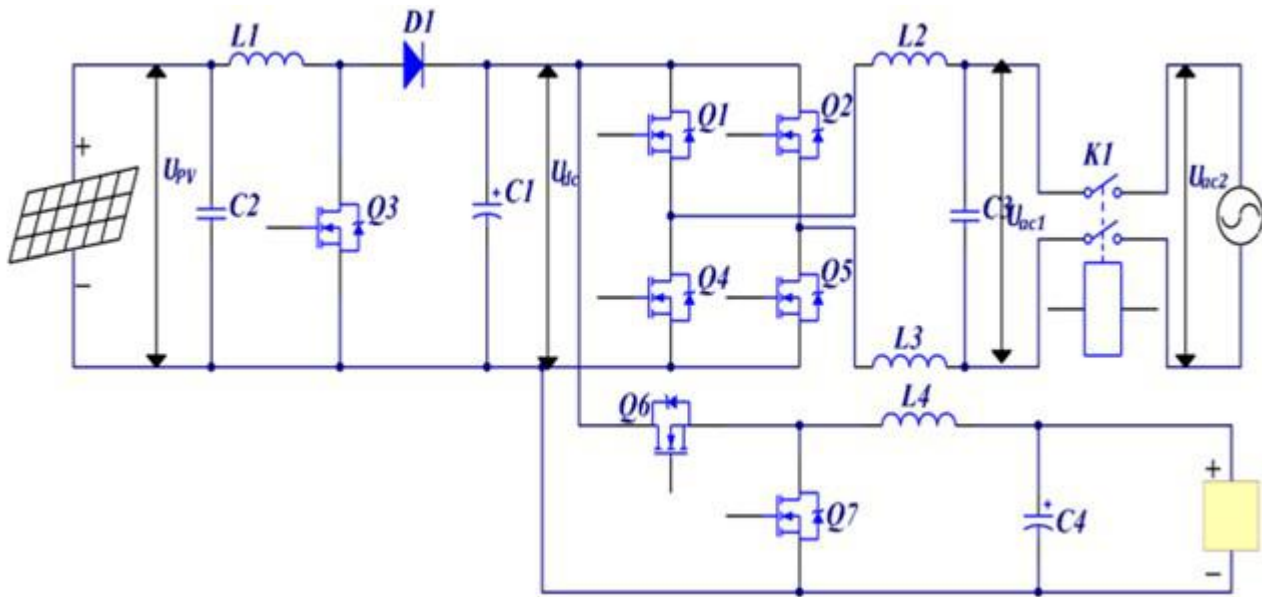

Figure 1: Schematic diagram of bidirectional energy storage grid-connected inverter

Bidirectional Converter

The bidirectional DC converter was connected to the DC bus. When the light intensity was sufficient, part of the energy generated by the solar panel was transferred to the grid while the rest was stored in the battery through the bidirectional DC converter. When the light was insufficient, the accumulator transmitted energy to supply electrical appliances and make grid-connected inverter acts as an uninterruptible power supply (UPS). A battery was incorporated to maintain the stability of the DC bus voltage and provide a guarantee for the stable output of the inverter.

Artificial Fish-swarm Algorithm

The newly developed algorithm works according to a two-step process. The first step involves a variable perturbation observation method to find the maximum power point of the system. In the second step, the proposed device makes use of the fish-swarm algorithm to rapid-search and track the global maximum power point. The PSpice software was used for the model simulation, which was aimed at obtaining the volt-ampere characteristic curve of PV system output. The solar array simulator was used to verify the effect of maximum power point tracking at different light intensities. Artificial fish swarm algorithm is a kind of swarm intelligence algorithm which is to simulate the fish in the nature of foraging, cluster and collision behavior and mutual assistance between fish swarm, so as to realize the global optimal. The algorithm was described as follows: The vector $S = (s_1, s_2, \dots, s_n)$ is denoted the state of artificial fish consisted of n fish, where $s_i (i = 1, 2, \dots, n)$ is for optimization of variable; Y express food concentration and then the food concentration of artificial fish i in the current position can be expressed as $Y_i = f(s_i)$; $d_{ij} = |s_i - s_j|$ represents the distance of artificial fish S_i and artificial fish S_j ; δ denoted crowded degree factor, expressed the crowded extent of artificial fish;

Step expressed maximum step length of ever movement of artificial fish; visual is the maximum range what artificial fish percept; try-number denotes the attempt times in the behavior of prey.

Results and Summary

Figure 1 shows the schematic diagram of the overall structure of the bidirectional energy storage photovoltaic grid-connected inverter. The front end of the system is the maximum power point tracker, the output DC bus voltage is U_{dc} , full bridge inverter, charge and discharge controllers are connected to the DC bus. The panel generates electrical energy that can be incorporated into the mains via the inverter and can store energy in the battery. However, the inverter is a bidirectional full-bridge inverter which can not only convert the DC bus power into AC power but also can convert 220 V mains into DC power to charge the battery. The charge-discharge controller is a bidirectional FIGURE 6 Boost mode working principle diagram [Colour figure can be viewed at wileyonlinelibrary.com] FIGURE 7 Schematic diagram of bidirectional dc converter [Colour figure can be viewed at wileyonlinelibrary.com] MOSES AND SUN 9 DC controller, which is a Buck circuit when the current flows from the DC bus to the battery and when the electric energy flows from the battery to the DC bus, it is a Boost circuit.

When the frequency increases, the copper and steel consumption's of the generator and transformer decrease, along with the reduction of weight and cost, but will make the inductance's of the electrical equipment and transmission line increase, reduce the capacitance's and increase losses, thereby reducing the transmission efficiency. If the frequency is too low, the electrical equipment's materials will increase, along with heavy and high cost, and will make lights flashing obviously. Practices have proved using 50 Hz and 60 Hz

frequencies are appropriate.

The open circuit voltage of the simulator was 193.785 volts, while the short circuit current was 2.6786 ampere. The ambient temperature was 27 C and the lighting power density was 1,000 W/m². The simulation showed that the MPPT tracking has an average efficiency of 99.5 percent and a maximum efficiency of 99.9 percent. According to the curves of the output power, voltage and current of the solar panel in 60 seconds and the Boost circuit can track the maximum power point around 10 seconds. The inverter is suitable for uninterrupted power supply in case of grid failure.

Article

Photovoltaic (PV) power systems and solar power Generation

Solar power generation: When sunlight strikes on photovoltaic solar panels solar electricity is produced. That is why this is also referred to as photovoltaic solar, or PV solar.

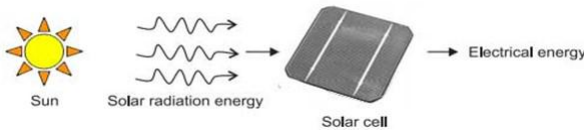

Figure 2: Solar power generation

Principles of Solar Electricity

Generation of electricity by using solar energy depends upon the photovoltaic effect in some specific materials. There are certain materials that produce electric current when these are exposed to direct sun light. This effect is seen in combination of two thin layers of semiconductor materials. One layer of this combination will have a depleted number of electrons. When sunlight strikes on this layer it absorbs the photons of sunlight ray and consequently the electrons are excited and jump to the other layer. This phenomenon creates a charge difference between the layers and resulting to a tiny potential difference between them. The unit of such combination of two layers of semiconductor materials for producing electric potential difference in sunlight is called solar cell.

Silicon is normally used as the semiconductor material for producing such solar cell. For building cell silicon material is cut into very thin wafers. Some of these wafers are doped with impurities. Then the un-doped and doped wafers are then sandwiched together to build solar cell. Metallic strip is then attached to two extreme layers to collect current. Conductive metal strips attached to the cells take the electrical current. One solar cell or photovoltaic cell is not capable of producing desired electricity instead it produces very tiny amount of electricity hence for extracting desired level of electricity desired number of such cells are connected together in both parallel and series to form a solar module or photovoltaic module.

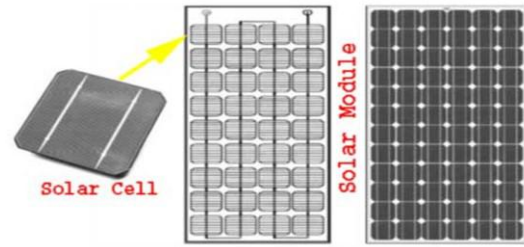

Figure 3: Principles of Solar Electricity

Application of Solar Electricity

Solar electric power generation system is useful for producing moderate amount of power. The system works as long as there is a good intensity of natural sunlight. The place where solar modules are installed should be free from obstacles such as trees and buildings otherwise there will be shade on the solar panel which affects the performance of the system. It is a general view that solar electricity is an impractical alternative of conventional source of electricity and should be used when there is no traditional alternative of conventional source of electricity available. But this is not the actual case. Often it is seem that solar electricity is more money saving alternative than other traditional alternatives of conventional electricity. It is always economical to install a solar light or a solar power source where it is difficult and costly to get point from local electric supply authority such as in remote garden, shed or garage where standard electric supply point is not available.

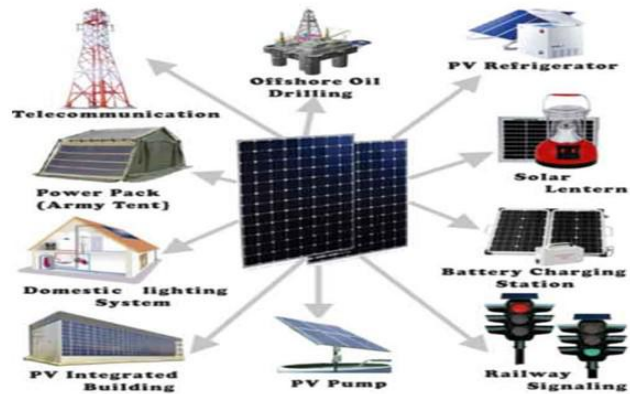

Figure 4: Application Solar Electricity

Article

Wind energy

Wind is a form of solar energy. Winds are caused by the un-even heating of the atmosphere by the sun, the irregularities of the earth's surface, and rotation of the earth. Wind flow patterns are modified by the earth's terrain, bodies of water, and vegetative cover. This wind flow, or motion energy, when "harvested" by modern wind turbines, can be used to generate electricity.

Wind Turbines

Wind turbines, like aircraft propeller blades, turn in the

moving air and power an electric generator that supplies an electric current. Simply stated, a wind turbine is the opposite of a fan. Instead of using electricity to make wind, like a fan, wind turbines use wind to make electricity. The wind turns the blades, which spin a shaft, which connects to a generator and makes electricity.

Wind Turbine Types

Modern wind turbines fall into two basic groups; the horizontal-axis variety, like the traditional farm windmills used for pumping water, and the vertical-axis design, like the eggbeater-style Darrieus model, named after its French inventor. Most large modern wind turbines are horizontal-axis turbines.

Turbine Components

Horizontal turbine components include: • blade or rotor, which converts the energy in the wind to rotational shaft energy; • a drive train, usually including a gearbox and a generator; • a tower that supports the rotor and drive train; and • Other equipment, including controls, electrical cables, ground support equipment, and interconnection equipment.

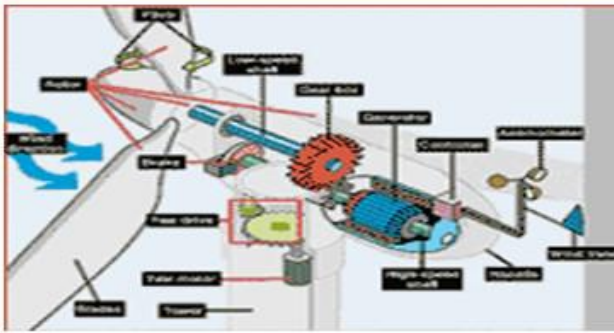

Figure 5: Wind turbine

Turbine Configurations

Wind turbines are often grouped together into a single wind power plant, also known as a wind farm, and generate bulk electrical power. Electricity from these turbines is fed into a utility grid and distributed to customers, just as with conventional power plants.

Wind Turbine Size and Power Ratings

Wind turbines are available in a variety of sizes, and therefore power ratings. The largest machine has blades that span more than the length of a football field, stands 20 building stories high, and produces enough electricity to power 1,400 homes. A small home-sized wind machine has rotors between 8 and 25 feet in diameter and stands upwards of 30 feet and can supply the power needs of an all-electric home or small business. Utility-scale turbines range in size from 50 to 750 kilowatts. Single small turbines, below 50 kilowatts, are used for homes, telecommunications dishes, or water pumping. Wind farms consist of many individual wind turbines which are connected to the electric power transmission network. Onshore wind is an inexpensive source of electricity, compet-

itive with or in many places cheaper than coal or gas plants. Offshore wind is steadier and stronger than on land, and offshore farms have less visual impact, but construction and maintenance costs are considerably higher. Small onshore wind farms can feed some energy into the grid or provide electricity to isolated off-grid locations.

Wind power is very consistent from year to year but has significant variation over shorter time scales. It is therefore used in conjunction with other electric power sources to give a reliable supply. As the proportion of wind power in a region increases, a need to upgrade the grid and a lowered ability to supplant conventional production can occur. Power management techniques such as having excess capacity, geographically distributed turbines, dispatch able backing sources, sufficient hydroelectric power, exporting and importing power to neighboring areas, using vehicle-to-grid strategies or reducing demand when wind production is low, can in many cases overcome these problems. In addition, weather forecasting permits the electricity network to be readied for the predictable variations in production that occur.



Figure 6: Offshore Wind power

Offshore wind power The world's second full-scale floating wind turbine (and first to be installed without the use of heavy-lift vessels), Wind Float, operating at rated capacity (2 MW) approximately 5 km offshore of Póvoa de Varzim, Portugal

Offshore wind power refers to the construction of wind farms in large bodies of water to generate electricity. These installations can utilize the more frequent and powerful winds that are available in these locations and have less aesthetic impact on the landscape than land based projects. However, the construction and the maintenance costs are considerably higher.

Siemens and Vestas are the leading turbine suppliers for offshore wind power. DONG Energy, Vattenfall and E.ON are the leading offshore operators. As of October 2010, 3.16 GW of offshore wind power capacity was operational, mainly in Northern Europe. According to BTM Consult, more than 16 GW of additional capacity will be installed before the

end of 2014 and the UK and Germany will become the two leading markets. Offshore wind power capacity is expected to reach a total of 75 GW worldwide by 2020, with significant contributions from China and the US.

Student Article

Power Flow Control in Power Transmission System by using UPFC

Introduction

Electrical power systems are a large interconnected network that requires a careful design to maintain the system with continuous power flow operation without any limitations. Flexible Alternating Current Transmission System (FACTS) is an evolving technology used to help electric utilities fully utilize their transmission assets. This concept was first introduced by N.G Hingorani, in 1988.

Many types of FACTS devices have been proposed, among them Unified Power Flow Controller (UPFC) is a versatile and flexible device in the FACTS family of controllers which has the ability to simultaneously control all the transmission parameters of power systems i.e. voltage, impedance and phase angle which determines the power flow of a transmission line.

The UPFC seen to be consists of two Voltage Source Converters (VSCs), one VSC is connected in series to the transmission line through a series transformer, similarly the other is connected in shunt to the transmission line through a shunt transformer and both are connected back to back through a D.C storage capacitor.

UPFC Operating Principle

The UPFC consists of two voltage source converters, one connected in series to the transmission line through a series transformer and the other in shunt to the transmission line through a shunt transformer, both are connected back to back through a DC link and can modelled as two ideal voltage sources between the two buses.

UPFC allows simultaneous control of active power flow, reactive power flow, and voltage magnitude at the UPFC terminals. Alternatively, the controller may be set to control one or more of these parameters in any combination or to control none of them. The active power demanded by the series converter is drawn by the shunt converter from the AC network and supplied to bus m through the DC link.

Following figure shows the voltage source model of the UPFC. Z_{se} and Z_{sh} are the impedances of the two transformers between the line and UPFC. In addition to providing a supportive role in the active power exchange that take place between a series converter and the AC system, the shunt converter may also generate or absorb reactive power in order to provide independent voltage magnitude regulation at its point of connection with the AC system.

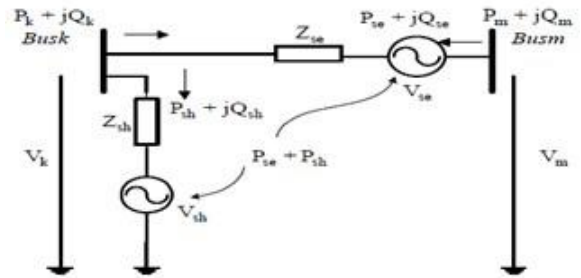

Figure 7: voltage source model of UPFC

Newton Raphson Algorithm and flowchart for incorporation in the UNIFIED POWER FLOW CONTROLLER

From the mathematical modelling point of view, the set of nonlinear, algebraic equations that describe the electrical power network under the steady state conditions are solved for the power flow solutions. Over the years, several approaches have been put forward to solve for the power flow equations. Early approaches were based on the loop equations and methods using Gauss-type solutions.

This method was laborious because the network loops has to be specified by hand by the systems engineer. The drawback of these algorithms is that they exhibit poor convergence characteristics when applied to the solution of the networks. To overcome such limitations, the Newton-Raphson method and derived formulations were developed in the early 1970s and since then it became firmly established throughout the power system industry.

Steps to Solve the Newton-Raphson Algorithm

Step 1: Read the input of the system data that includes the data needed for conventional power flow calculation i.e. the number and types of buses, transmission line data, generation, load data and location of UPFC and the control variables of UPFC i.e. the magnitude and angles of output voltage series and shunt converters.

Step 2: Formation of admittance matrix Y_{bus} of the transmission line between the bus i and j.

Step 3: Combining the UPFC power equations with network equation, we get the conventional power flow equation:

Step 4: The conventional jacobian matrix are formed due to the inclusion of UPFC. The inclusion of these variables increases the dimensions of the jacobian matrix.

Step 5: In this step, the jacobian matrix is modified and power equations are mismatched

Step 6: The bus bar voltages are updated at each iteration and convergence is checked.

Step 7: If convergence is not achieved in the next step the algorithm goes back to the step 6 and the jacobian matrix is modified and the power equations are mismatched until convergence is attained.

Step 8: If the convergence achieved in Step 7, the output load flow is calculated for PQ bus that includes the Bus bars voltages, generation, transmission line flow and losses.

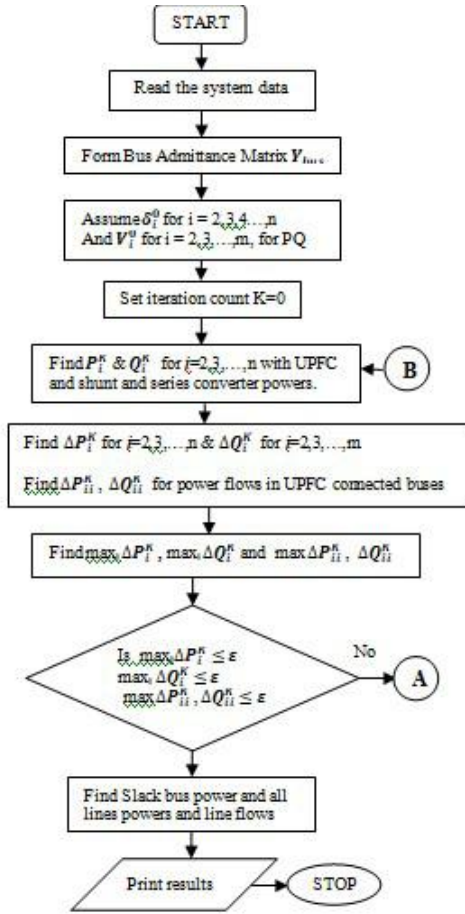

Figure 8: Flowchart for N-R method

Student Article
DC/DC Power Supplies
Introduction

With the introduction of the transistor in the early 1950's and, especially, with the development of integrated circuits from the early 1960's on wards (Josephson 1967), designers of electronic equipment, computers and instrumentation increasingly have brought up the demand for smaller, more efficient power sources to supply their equipment. Therefore, to meet these demands, the power supply itself has become more and more sophisticated. In fact, the development in power supply technology can be directly linked to the introduction of various power semiconductor devices.

The regulated power supply technology can be divided into two distinct forms: firstly, the linear regulator which can be either a series or parallel regulator and, secondly, the switched mode conversion technique. Switched-mode technology is multi-faceted with a wide variety of topology achieving the result of providing a regulated DC voltage.

The main difference between the linear and switched-mode regulator is in efficiency. The linear regulator utilizes simple techniques of controlled energy dissipation to achieve a regulated output voltage independent of line and load variations. It is, therefore, inherently inefficient, especially when a wide input voltage range has to be applied. When linear techniques

are applied to regulate a low voltage from the mains (110V or 240V AC source) then the disadvantages of the technique become apparent.

Linear Power Supply

Linear power supplies provide significant advantages over switching regulators in: Simplicity, Cost, and Output noise.

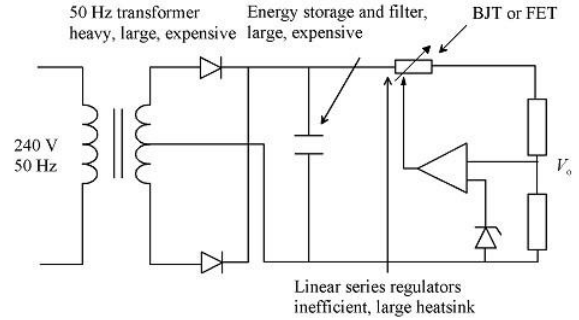

Figure 9: Practical linear series regulator circuit

The efficiency is lower compared to the switched mode power supply. A typical linear power supply is shown in following figure, which has the following disadvantages:

- i. The main transformer operating at a low frequency is heavy, large and expensive, ii. Large heat-sinking is required to dissipate the heat generated by the regulating element, and
- iii. The efficiency is low.

Switched Mode Power Supply

Switched-mode power supply shown below offers the possibility of theoretically lossless power conversion, which is not true in reality. The switched-mode regulator employs duty cycle control of a switching element to block the flow of energy and thus achieve regulation.

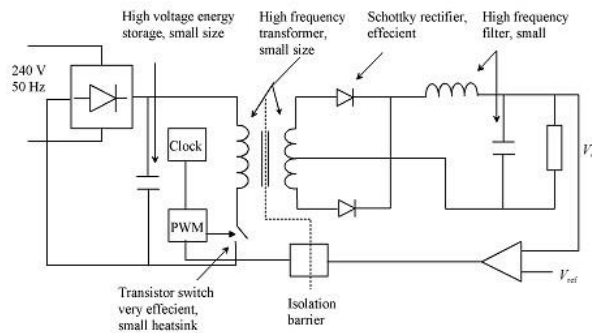

Figure 10: Practical circuit of switch mode regulator

This topology has more advantages compared to linear regulators. The switched mode power supply has the following advantages compared to the linear regulator:

- a. High switching frequency enables the use of a small ferrite transformer core.
- b. Since the rectified mains voltage is chopped, the energy storage for hold-up can be accomplished on the primary side of the step-down transformer.

c. Smaller but high voltage capacitors than in the linear counterpart can be used.

d. It can step the voltage up/down and reverse its polarity.

e. It may operate in a much larger DC input voltage range than the linear regulators, and

f. It often has a higher efficiency.

Although the benefits of switched-mode techniques are significant, there are some drawbacks:

a. Both the input and output present increased noise of the supply due to the power switching techniques.

b. The associated control circuitry is more complicated compared to the linear counterpart, e.g. an isolated feedback signal is needed for the control.

Student Article

Economic Load Dispatch

Introduction

The use of electricity is absolutely necessary in modern day-to-day life. The quality of electricity is stated in terms of constant voltage, constant frequency and uninterrupted power supply at minimum cost. To provide uninterrupted power supply and to return profit on the capital investment we need to cut down the cost of generation of electricity. That means proper operation is very important. There are many factors involved in the successful operation of a power system.

The system is expected to supply power instantaneously and continuously to meet customer's demands under all operating conditions. It is also expected that the voltage supplied to the consumers need to be maintained at or near the nominal rated value. For this proper operating procedure must be observed to avoid damage to equipment or other facilities of the system. All of these operating requirements must be achieved simultaneously with minimum cost for production and distribution of power.

Economic factors influenced by actions of operating personnel include the loading of generating equipment, particularly of thermal units, where efficiency of unit and fuel costs are major factors in the cost of power production. Purchase power availability, cost and scheduling of overhaul and or repairs of equipment all affect operating costs. The cost of generation includes the fixed costs (like salaries and capital cost etc) and Variable costs (like fuel cost, maintenance cost and operation cost etc).

An engineer is always concerned with cost of Product and Services. For a power system to return a profit on the capital invested, proper operation is very important. The global energy crisis made it necessary that we must produce more power from the available resources. Rates fixed by regulatory bodies and the importance of conservation of fuel place extreme pressure on power companies to achieve maximum efficiency of operation and to improve efficiency continually in order to maintain a reasonable relation between cost of KWhr to a consumer and the cost to the company of delivering a KWhr in view of constantly rising prices for fuel, labor, supplies and maintenance.

Economic dispatch problem can be defined as the determination of "For any specified load (PD) condition, calculation of the power output of each plant (and each generating unit

within a plant) which will minimize the overall cost of fuel needed to serve the system load".

To determine the economic distribution of load between the various units consisting of a turbine, generator, and steam supply the variable operating costs of the unit must be expressed in terms of power output. Fuel cost is the principal factor in fossil-fuel plants, most of our electrical energy will continue to come from fossil fuels. We shall base our discussion on the economics of fuel cost with the realization that other costs which are a function of power output can be included in the expression of fuel cost.

The criterion for distribution of the load between any two units is based upon whether increasing the load on one unit as the load is decreased on the other unit by the same amount results in an increase or decrease in total cost. Thus, we are concerned with incremental cost, which is determined by the slopes of the input -vs- output curves of the two units.

Incremental fuel cost for any given power output is the ratio of the increase in cost of fuel input in currency unit Rupee / hr. to the corresponding increase in power output in MW . Approximately, the incremental fuel cost could be obtained by determining the increased cost of fuel for a definite time interval during which power output is increased by a small amount. For instance, the approximate incremental cost at any particular output is the additional cost in Rupee/hr to increase the output by 1 MW.

Development of Economic Load Dispatch Methods

The progress of optimal dispatch goes far back as the early 1920's, when engineers were concerned with the problem of economic allocation of generation or the proper division of the load among the generating units available.

Prior to 1930, various methods were in use such as: (a) the base load method where the next most efficient unit is loaded to its maximum capability, then the second most efficient unit is loaded, etc., (b). "best point loading," where units are successively loaded to their lowest heat rate point, beginning with the most efficient unit and working down to the least efficient unit, etc.

It was recognized as early as 1930, that the incremental method, later known as the "equal incremental method," yielded the most economic results. In 1954, co-ordination equation was developed for solving economic dispatch problem. A breakthrough in the mathematical formulation of the economic dispatch problem was achieved by Carpentier in the early 1960's who treated the entire work in an exact manner.

The solution of Carpentier's formulation is a non-linear optimization which has been the subject of much study though the present and its implementation in real time remains a challenge.

Definition of Economic dispatch

Economic dispatch problem means that determination of generation of different units such that total fuel cost is minimum and at the same time total demand and losses at any instant must be met by total generation.

Cost of Electric Energy

The cost of electrical energy produced depends on two factors:

1.Fixed cost These are the costs which are independent of plant operation. This consists of: a) Capital cost of power plant b) Interest on capital, taxes and insurance c) Salaries of management and clerical staff d) Depreciation

2. Running cost This cost varies proportional to the electric energy produced in KWhr and is consists of: a) Cost of fuel b) Operation cost of the plant in terms of the salaries of the labour and technical staff c) Maintenance cost

Economic Load Dispatch - Thermal Stations

A power system is a mix of different type of generations, out of which thermal, hydro and nuclear power generations contribute the active share. However, economic operation has conveniently been considered by proper scheduling of thermal or hydrogenation only. As for the safety of nuclear station, these types of stations are required to run at its base loads only and there is a little scope for the schedule of nuclear plants in practice.

Economy of operation is most significant in case of thermal stations, as the variable costs are much higher compared to other type of generations. This can be considered by looking at various costs of different stations.

Cost	Thermal station	Hydro station	Nuclear station
Fixed costs	20%	75%	70%
Fuel cost	70%	0	20%
Other operational costs	10%	25%	10%

Figure 11: Various Costs of different Stations

Generator Operating Cost Curves

The major component of the generator operating cost is the fuel input/hour, while maintenance contributes only to a small extent. The fuel cost is meaningful incase of thermal and nuclear stations. But for the hydro station where the energy storage is ‘apparently free’, the operating cost of such is not meaningful. The different operating cost curves are: i. Input output curve. ii. Incremental fuel cost curve.

Input Output Curve

The input output curve of a unit can be expressed in million kilo calories per hour or directly in terms of Rs/hr versus output in megawatts. The cost curve can be determined experimentally. A typical curve is shown in the figure below.

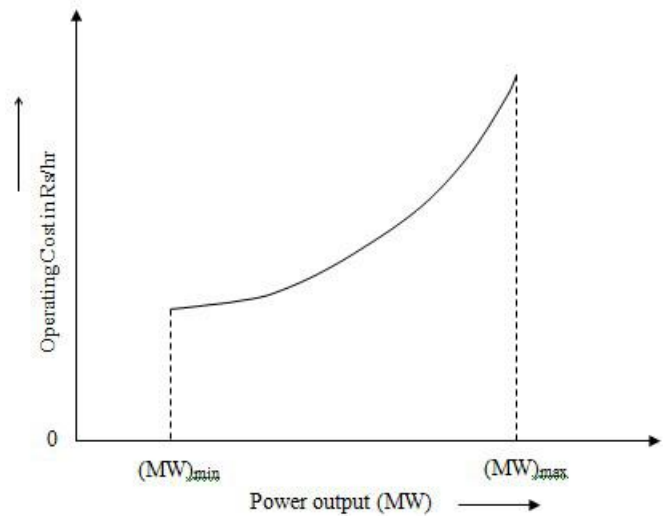

Figure 12: Input-Output curve of a generating unit

Incremental Fuel Cost Curve

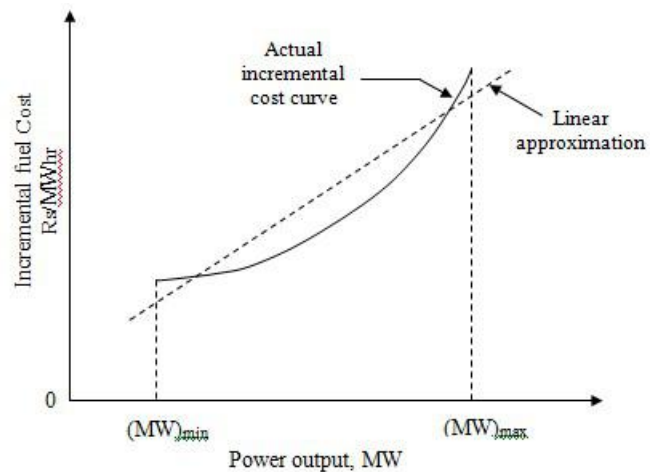

Figure 13: Incremental fuel cost vs. power out put

A typical plot of Incremental fuel cost vs. power out put curve is shown above. For better accuracy incremental fuel cost may be expressed by a number of short line segments (piece-wise linearization) alternatively we can fit a polynomial of suitable degree to represent IC curve in the inverse form equation.

Economic Load Dispatch Problem

The objective of economic load dispatch of electric power generation is to schedule the committed generating unit outputs so as to meet the load demand at minimum operating cost while satisfying all units and operational constraints of the power system.

The economic dispatch problem is a constrained optimization problem and it can be mathematically expressed as follows:

$$\text{Minimize } FT = \sum F_i(P_i)$$

Where, FT : total generation cost (Rs/hr) n : number of generators P_i : real power generation of ith generator (MW)

$F_i(P_i)$: generation cost for P_i

System Active Power Balance

For power balance, an equality constraint should be satisfied. The total power generated should be the same as total load demand plus the total line losses $P_D + P_L - \sum P_i = 0$
Where, P_D : total system demand (MW) P_L : transmission loss of the system (MW)

Generation Limits Generation output of each generator should be laid between maximum and minimum limits. The corresponding inequality constraints for each generator are: $P_{n,min}$ less than or equal to P_n less than or equal to $P_{n,max}$

Network Losses

Since the power stations are usually spread out geographically, the transmission network losses must be taken into account to achieve true economic dispatch. Network loss is a function of unit generation. To calculate network losses, two methods are in general use. One is the penalty factors method and the other is the B coefficients method. The latter is commonly used by the power utility industry. In the B coefficients method, network losses are expressed as a quadratic function:

$$P_L = \sum P_m B_{mn} P_n$$

Where, B_{mn} are constants called B coefficients or loss coefficients.

Article: A Hybrid Wind-Solar Energy System: A New Rectifier Stage Topology - By N.C. Alluraiah

INTRODUCTION With increasing concern of global warming and the depletion of fossil fuel reserves, many are looking at sustainable energy solutions to preserve the earth for the future generations. Other than hydro power, wind and photovoltaic energy holds the most potential to meet our energy demands. Alone, wind energy is capable of supplying large amounts of power but its presence is highly unpredictable as it can be here one moment and gone in another. Similarly, solar energy is present throughout the day but the solar irradiation levels vary due to sun intensity and unpredictable shadows cast by clouds, birds, trees, etc. The common inherent draw-

back of wind and photovoltaic systems are their intermittent natures that make them unreliable. However, by combining these two intermittent sources and by incorporating maximum power point tracking (MPPT) algorithms, the system's power transfer efficiency and reliability can be improved significantly. When a source is unavailable or insufficient in meeting the load demands, the other energy source can compensate for the difference. Most of the systems in practice use a separate DC/DC boost converter connected in parallel in the rectifier stage as shown in Figure 1 to perform the MPPT control for each of the renewable energy power sources.

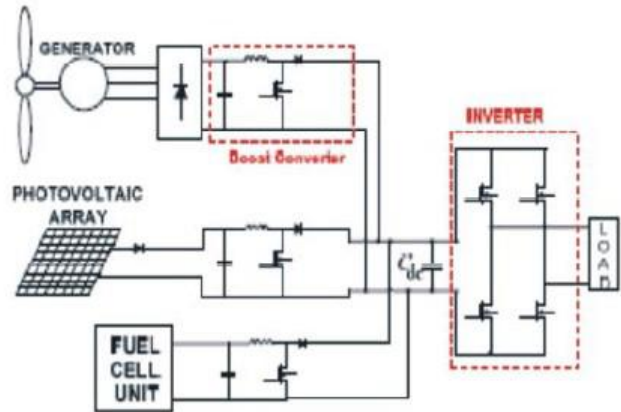

Figure 14: Hybrid system with multi-connected boost converter

The structure is a fusion of the buck and buck-boost converter. This system requires passive input filters to remove the high frequency current harmonics injected into wind turbine generators. The harmonic content in the generator current decreases its lifespan and increases the power loss due to heating.

+919848998641



 AnnamacharyaGroup

ANNAMACHARYA INSTITUTE OF TECHNOLOGY AND SCIENCES :: RAJAMPET

An Autonomous Institution

■ Established in 1998 ■ Approved by AICTE, New Delhi ■ Affiliated to JNT University, Anantapur
 ■ NAAC Accreditation ■ IE(I) Accreditation ■ 2(f) & 12(B) as per UGC act 1956 ■ Research Center approved by JNTUA
 RAJAMPET | KADAPA (Dist) | AP | 516126 | ☎ 08565-251861/62/63 | 📠 08565-251864 | www.aitrajampet.ac.in

Develop success from failures. Discouragement and failure are two of the surest stepping stones to success.